

BW30 & BW50 Chair Rail

Recommended Installer Qualifications: Only those parties experienced in working with finished fine wood products should engage in installing Korowood™ BW30 and BW50 Chair Rails

Recommended Installation Equipment: Radial Arm Saw or Power Miter Box with 12" (304.8mm) sharp carbide-tipped Alternating Tooth, Bevel-Positive Hook, 80-100 teeth blade. Tape Measure, Level, Chalk Line, Utility Knife, Drill, Drill Bits, Screwdriver, Sanding Block, Wood Glue, Removable Marker, Cleaning Cloth, Suitable No. 8 x 3" (76.2mm) Long Trim-Head Finishing Screws (or Equal), and Finishing Nails.

1. Locate and install Korowood Chair Rail in accordance with architectural drawings and specifications. When required, Korogard shop drawings should be used in conjunction with these documents.
2. Lay out work to be completed, including all component parts, along base of substrate (wall). Check material for any damage that may have occurred during shipment and/or handling at job site.
3. Snap chalk line at proper location on substrate to ensure level installation. Chalk line should be calculated to locate bottom edge of Chair Rail.

Note: Chalk line may be visible after installation and may require removal at cleanup.

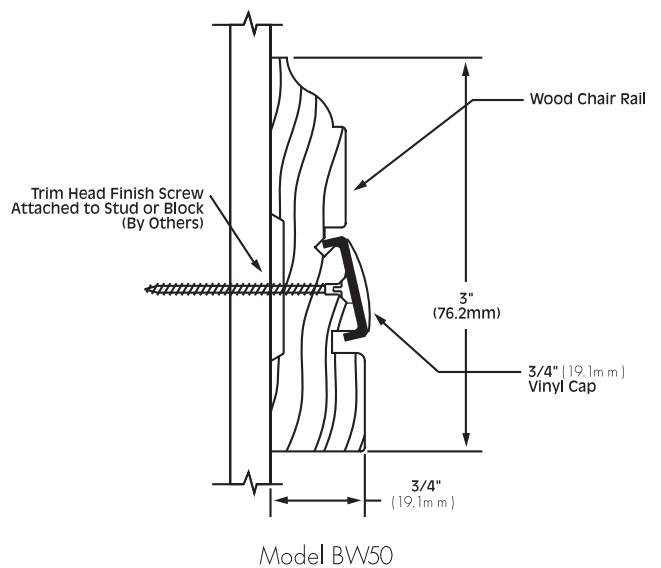
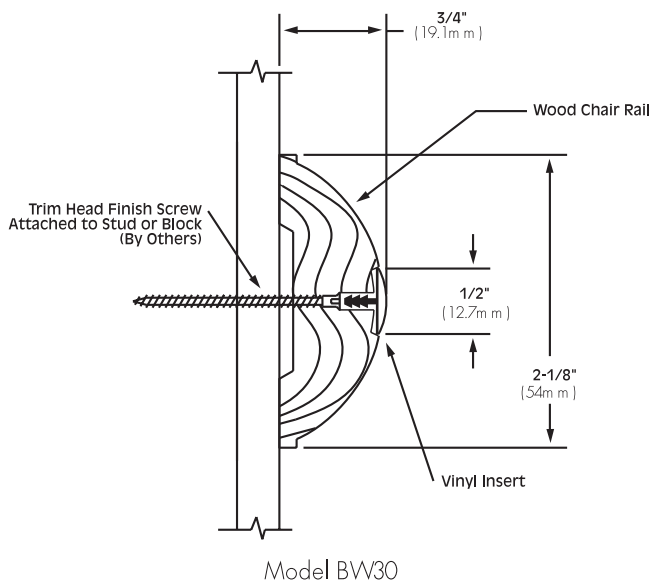

4. Determine cut length of rail by locating ends on substrate, measure distance, and allow 3/4" (19.05mm) at end cap, 0" (0mm) at substrate inside corners, and 0" (0mm) at substrate outside corners. Mark Chair Rail at back of wood and miter-cut rail in appropriate direction to appropriate length. Miter ends at outside corners, inside corners, and splices to 45° (see details). Use care to ensure accurate and clean cuts. (Wrap finished rail with masking tape at location of cut and cut so that saw blade rotates into face of rail as it cuts).
5. Drill and countersink appropriately-sized holes through Chair Rail along and beneath vinyl cap and insert location at 3" (76.2mm) to 6" (152.4mm) in from each end of rail and intermediate locations not exceeding 32" (812.8mm) O.C.
6. Trial-fit End Caps/Adjoining Piece to ensure proper fit. If satisfactory, ensure that surfaces to be glued are clean and unfinished (sand if required) and glue, using PVA wood glue or equal (supplied by installer), adjoining parts together, carefully aligning parts. Allow glue to set and wipe any excess from joint with water-moistened cloth. Use two finishing nails, one near the top and one near the bottom, through the cap into the rail end and finish with wood filler.
7. Mount assembly to substrate using proper fasteners (supplied by installer). Tighten securely.
8. Vinyl cap and insert is to be mitered at corners in the same manner as wood rail. Determine cut length of vinyl insert by measuring face of rail. Mark the measurements on the vinyl, using a soft pencil or other removable marker, at point where back of vinyl contacts face Chair Rail. Cut ends of vinyl to 45° in the appropriate direction, using a scrap piece of chair rail as holding fixture if necessary. Cut vinyl slightly longer than rail to ensure tight joints.
9. Install Korogard vinyl cap/insert starting at one end and progressing to the other.
Note: Prior to installation of Korogard vinyl cap / insert strip, make sure all fasteners are secured and properly seated.
10. Clean Chair Rail using water-moistened cloth. If necessary, use the Korowood™ Touch-Up Kit provided to repair stained wood where minor damages or blemishes may have occurred during handling and installation. Touch-Up Kits are not provided for "clear varnish" finished Chair Rails. Use Minwax brand "Satin Sheen Polyurethane" or equal to overcoat repair to all finishes.
11. If you have any questions during installation, please contact your local Korogard representative.

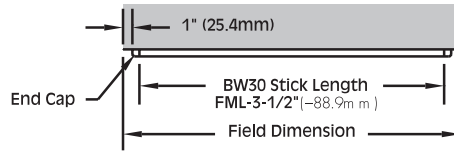

BW30 Typical Termination Application

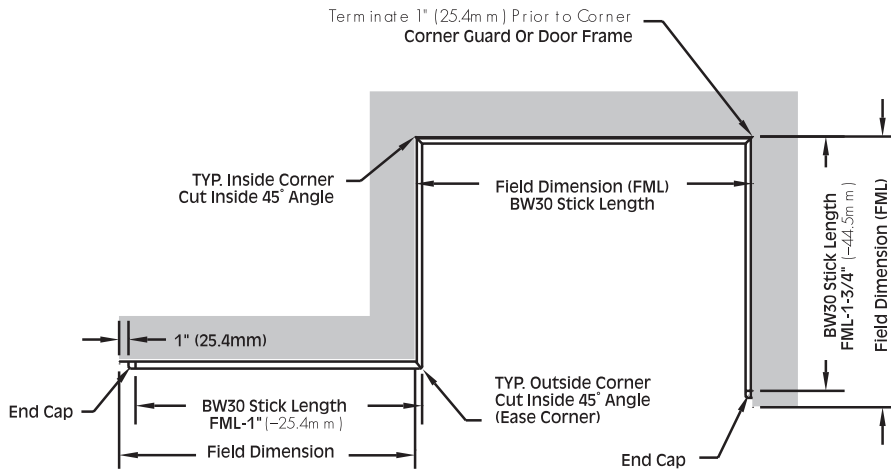

BW30 Plan View

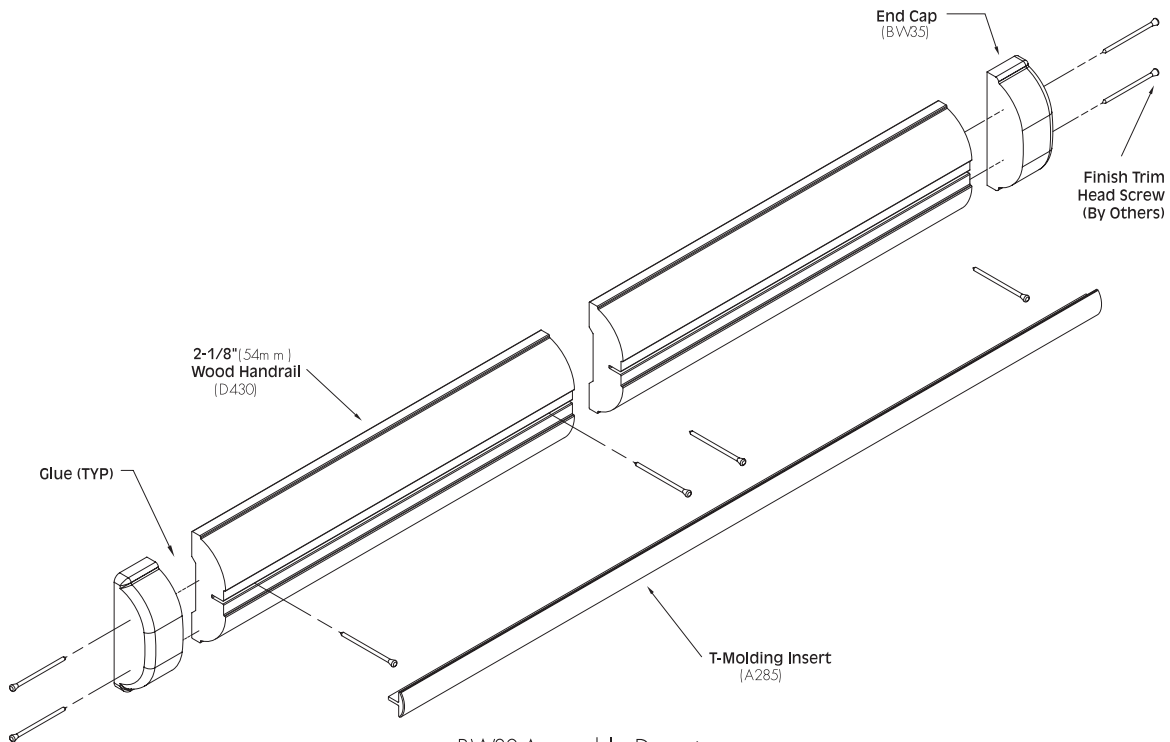

BW30 Assembly Drawing

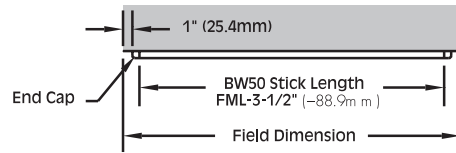

BW50 Typical Termination Application

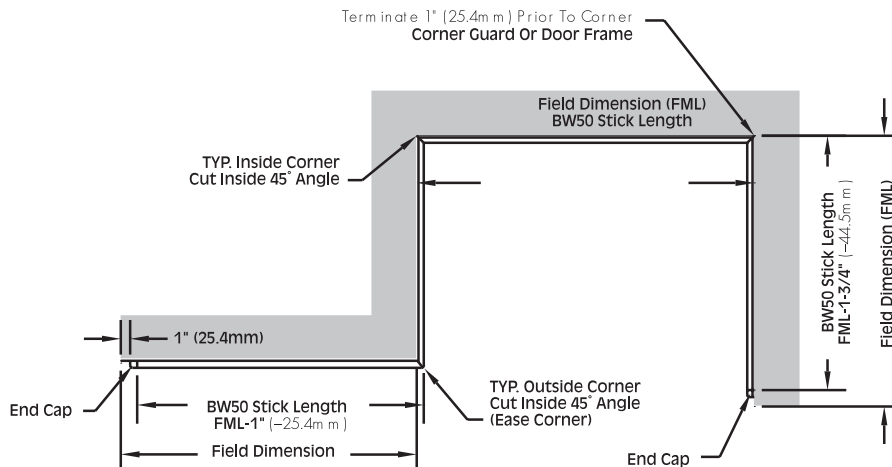

BW50 Plan View

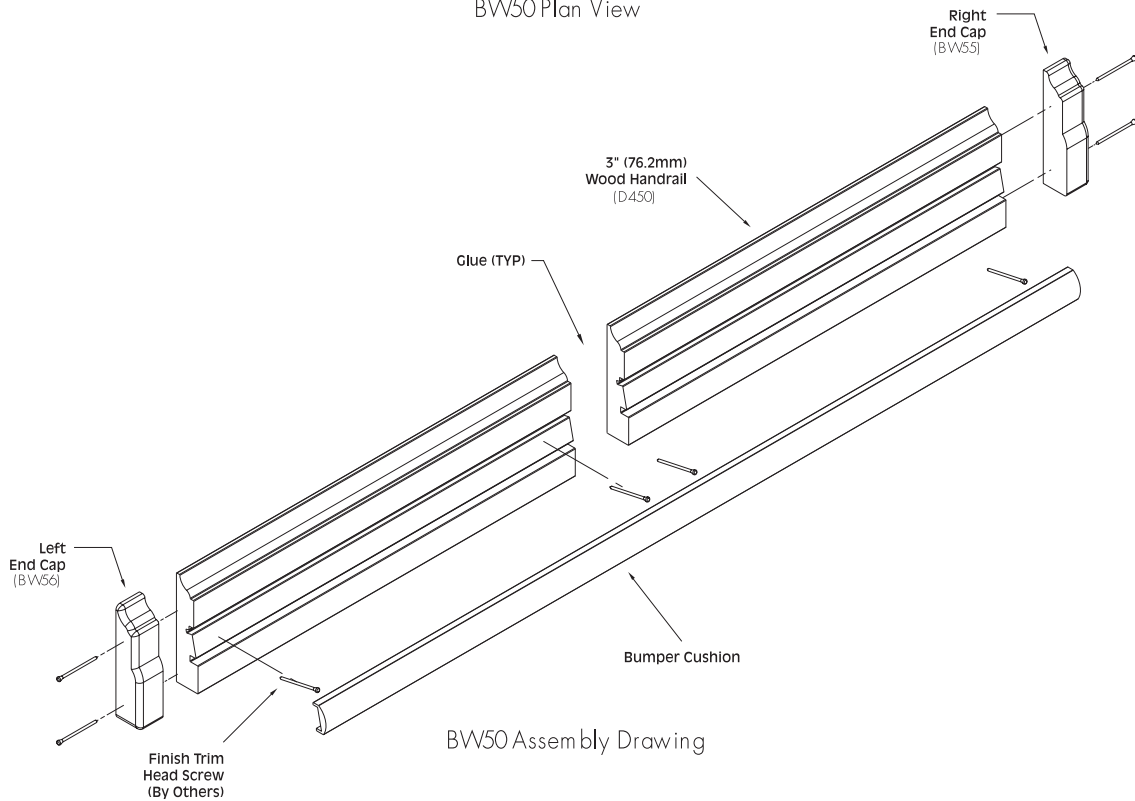

BW50 Assembly Drawing